

DIGITAL INSULATION TESTER

INSTRUCTION MANUAL

ZICO ZI-9100

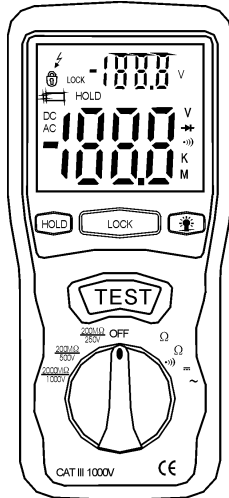

SAFETY INFORMATION

- Read the following safety information carefully before attempting to operate or service the meter.
- To avoid damages to the instrument do not apply the signals which exceed the maximum limits shown in the technical specifications tables.
- Do not use the meter or test leads if they look damaged. Use extreme caution when working around bare conductors or bus bars.
- Accidental contact with the conductor could result in electric shock.
- Use the meter only as specified in this manual; otherwise, the protection provided by the meter may be impaired.
- Read the operating instructions before use and follow all safety information.
- Caution when working with voltages above 60V DC or 30V AC RMS. Such voltages pose a shock hazard.
- Before taking resistance measurements or testing acoustic continuity, disconnect circuit from main power supply and all loads from the circuit.

Safety symbols:



Caution refer to this manual before using the meter.



Dangerous voltages.



Meter is protected throughout by double insulation or reinforced insulation.

When servicing, use only specified replacement parts.

CE Comply with EN-61010-1

1. SPECIFICATIONS

1-1 General Information

Environment conditions:

- ① Installation Categories II
- ② Pollution Degree 2
- ③ Altitude up to 2000 meters
- ④ Indoor use only
- ⑤ Relatively humidity 80% max.
- ⑥ Operation Ambient 0~40°C

Maintenance & Clearing:

- ① Repairs or servicing not covered in this manual should only be performed by qualified personnel.
- ② Periodically wipe the case with a dry cloth. Do not use abrasives or solvents on this instruments.

Display: Large LCD with dual display

Measurement Range: 200Ω, 200kΩ, 200MΩ/250V,
200MΩ/500V, 2000MΩ/1000V,
750V/ACV, 1000V/DCV.

Sampling Rate: 2.5 times per second.

Zero Adjustment: Automatic adjustment.

Over Range Indicator: Number 1 of highest digit is displayed.

Low Battery Indication: The  is displayed when the battery Voltage drop below the operating voltage.

Operating Temperature: 0°C to 40°C (32°F to 104°F) and Humidity below 80% RH

Storage Temperature: -10°C to 60°C (14°F to 140°F) and Humidity below 70% RH

Power source: DC9V (6x1.5V Size "AA" battery or Equivalent)

Dimensions: 200(L) x 92(W) x 50(H) mm

Weight: Approx 700g include battery

Accessories: Test leads, 6pcs battery, Carrying case, manual.

1-2 Electrical Specifications

Accuracies are specified in the way:

$\pm(\dots\% \text{ of reading} + \dots \text{ digits})$ at $23^{\circ}\text{C} \pm 5^{\circ}\text{C}$, below 80% RH.

OHMS

Range	Resolution	Accuracy	Max. open Circuit Voltage	Overload Protection
200 Ω	0.1 Ω	$\pm(1\%+2)$	4.5V	250Vrms
200k Ω	0.1k Ω		3.0V	

Continuity Beeper

Range	Resolution	Operation Resistance	Max.open Circuit Voltage	Overload Protection
•)))	0.1 Ω	Resistance \leq 40 Ω	4.5V	250Vrms
Short circuit current		\leq 200mA		

DC Voltage

Range	Resolution	Accuracy	Input Impedance	Overload Protection
1000V	1V	$\pm(0.8\%+3)$	10M Ω	1000Vrms

AC Voltage (40Hz~400Hz)

Range	Resolution	Accuracy	Input Impedance	Overload Protection
750V	1V	$\pm(1.2\%+10)$	10M Ω	750Vrms

Meg OHMS

Range	Resolution	Accuracy	Terminal Voltage
200M Ω /250V	0.1M Ω	$\pm(3\%+5)$	250V+10%~-0%
200M Ω /500V	0.1M Ω		500V+10%~-0%
0~1000M Ω /1000V	1M Ω	$\pm(5\%+5)$	1000V+10%~-0%
1000~2000M Ω /1000V			

Range	Test Current		Short circuit current
200M Ω /250V	1mA	250K Ω (load)	\leq 1mA
200M Ω /500V		500K Ω (load)	
0~1000M Ω /1000V		1M Ω	
1000~2000M Ω /1000V			

2. PARTS & CONTROLS

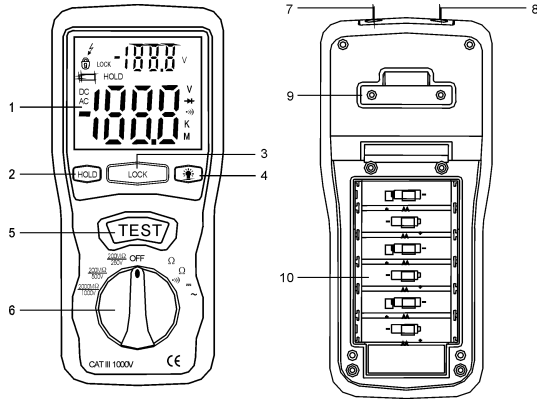

- ① Digital Display
- ② Data Hold Button
- ③ Lock Button
- ④ Backlight Button
- ⑤ Test Button
- ⑥ Rotary Function switch
- ⑦ VΩ Jack
- ⑧ COM input jack
- ⑨ Pothook
- ⑩ Battery Cover

3. BATTERY REPLACEMENT

3-1 How to connect test leads.

- a). On MΩ Range: Connect the red test lead into the “VΩ” terminal and the black lead into the “COM” terminal.
- b) On 200Ω and ACV Range: Connect the red test lead into the “VΩ” terminal and the black lead into terminal “COM”

3-2 Battery Check-UP & Replacement

- a) As battery power is not sufficient. LCD will display . Replacement of 6 pcs new batteries, type 1.5V size “AA” is Required.
- b). Place back the battery cover and four the screws.

3-3 Test leads check

Set the range select switch to the 200Ω range. With the tip and alligator clip of the test leads connected. The indicator should read 00.0Ω. When the leads are not connected the display will read infinity indicated by “1”. This will ensure that test lead are under working condition.

4. INSULATION RESISTANCE MEASUREMENTS

- a). Measurements at 200MΩ/250V This is the voltage used for the majority of insulation resistance tests on normal installation requirement. To measure insulation resistance, press the test button to power on the tester. The LCD will displayed the insulation resistance. Section VII indicated

that subdivision of large installations might be necessary because of the large number of parallel insulation resistance. In such a case, an installation may be divided into sections, each being separately tested. Each section must have not less than fifty outlets, an outlet being a switch, socket, lighting point etc. A switched socket counts as one outlet. The minimum acceptable insulation resistance is $1M\Omega$. For a large installation, the capacitance of the insulation will be high, and it will take longer for it to become charged by the direct testing voltage. Care must be taken not to take a reading until there is a steady reading, indicating that the charging process is complete.

Note: The charge stored in the insulation will be discharged automatically when the test button is released. Be careful not to turn the range switch knob whilst the test button is pressed, or the instrument will be damaged.

b). Measurements at 2000M Ω /1000V

Some specifications require testing at 1000V. This voltage must also be selected where the supply voltage of the installation is between 500V and 1000V. First, set the range switch to 1000V and then proceed as indicated in a above for 500V testing. The above note also applies to testing at 1000V. In addition the following applies.

Note: Make sure that the circuit under does not include components Which will be damaged by the 1000V applied. Many normal components of an installation are

likely to be damaged if tested at 1000V. Examples are power factor correction capacitors, low voltage mineral insulated cables, electronic light dimmers, electronic ballasts and starters for fluorescent lamps etc...

c). Lock power on Feature

For hands free operation a lock power on feature is incorporated on the press to test button. Set LOCK button to lock test voltage, Pressing it again will tester off.

5. LOW RESISTANCE (CONTINUITY) MEASUREMENTS

- a). Set the range switch to 200 Ω))) Position
- b). Connect the red test lead to the V Ω terminal and black to the COM terminal.
- c). Connect the tips of the test leads to both ends of the circuit under test. read resistance in Ω on the LCD.
- d). When the impedance on circuit is below approximately 40 Ω .It will indicate by a continuous beeper.

6. AC/DC VOLTAGE MEASUREMENTS

- a). Set the range switch to ACV or DCV position
- b). Connect red test lead to "V Ω " terminal and black test lead to terminal "COM".
- c). Connect test prods of test leads IN PARALLEL to the circuit being measured.
- d). Read the voltage value on LCD.

7. POWER TOOLS AND SMALL APPLIANCES

This test would also apply to other similar equipment that has a line cord. For double insulated power tools, the megohmmeter lead shown connected to the housing would be connected to some metal part of the tool (e.g. chuck, blade). Note: The switch of the device must be in the "ON" position and the main power should be disconnected.

MOTORS

AC-Disconnect the motor from the line by disconnecting the wires at the motor terminals or by opening the main switch. If the main switch is used and the motor also has a starter then the starter must be held, by some means, in the "ON" position. In the latter case, the measured resistance will include the resistance of the motor, wire and all other components between the motor and the main switch. If a weakness is indicated, the motor and other components should be checked individually. If the motor is disconnected at the motor terminals, connect one megohmmeter lead to the grounded motor housing and the other lead to one of the motor leads. DC-Disconnect the motor from the line. To test the brush rigging, field coils and armature connect one megohmmeter lead to the grounded motor housing and the other lead to the brush on the commutator. If the resistance measurement indicates a weakness, raise the brushes off the commutator and separately test the armature, field coils and

brush rigging by connecting one megohmmeter lead to each of them individually, leaving the other connected to the grounded motor housing. The above also applies to DC Generators.

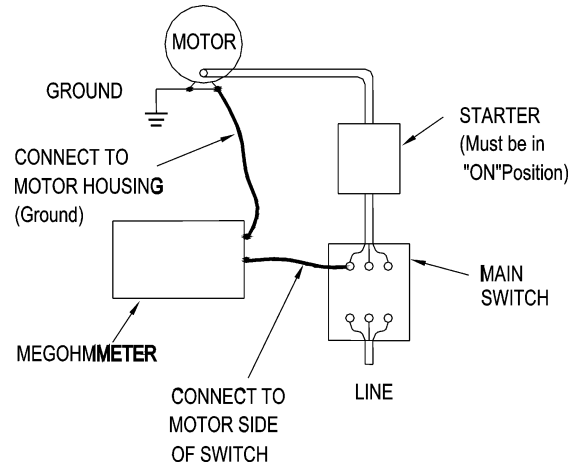

CABLES

Disconnect the cable from the line. Also disconnect opposite end to avoid errors due to leakage from other equipment. Check each conductor to ground and /or lead sheath by connecting one megohmmeter lead to a ground and /or lead sheath and the other megohmmeter lead to each of the conductors in turn. Check insulation resistance between conductors by connecting megohmmeter leads to conductors in pairs.

